

# Instruction Manual

# X4 atom<sup>®</sup>



## PSU12

from software version: v1.21



— since 1994 —

[support@glp.de](mailto:support@glp.de)

[www.glp.de](http://www.glp.de)

# Contents

1	Description of Device.....	3
2	Safety Instructions .....	4
3	Mounting.....	5
3.1	Operating on the floor, on a table or in a Rack.....	5
3.2	Mounting in a hanging or sideways position .....	5
3.3	Securing the Fixture.....	6
4	Connections .....	7
4.1	Power Supply .....	7
4.2	DMX.....	8
4.3	Output to X4 ATOM Head.....	8
5	The Menu Field .....	8
6	DMX Channel Selection (DMX Protocol) .....	11
6.1	Normal Mode (norm) 110 DMX Channels: .....	11
7	Maintaining and Cleaning .....	20
7.1	Safety regulations.....	20
7.2	Maintenance and Interval (rule-of-thumb) .....	20
8	Technical Specifications: .....	21
9	Dimensions.....	22

## 1 Description of Device

1. LCD-Display / Menu (data entry)
2. Safety wire attachment point (2x)
3. Fan in/outlet (2x)
4. Connector panel (see below)

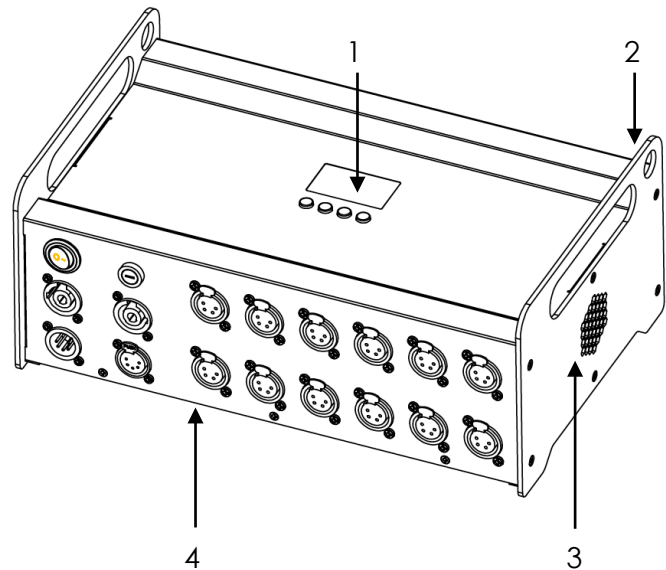

### Connector Panel

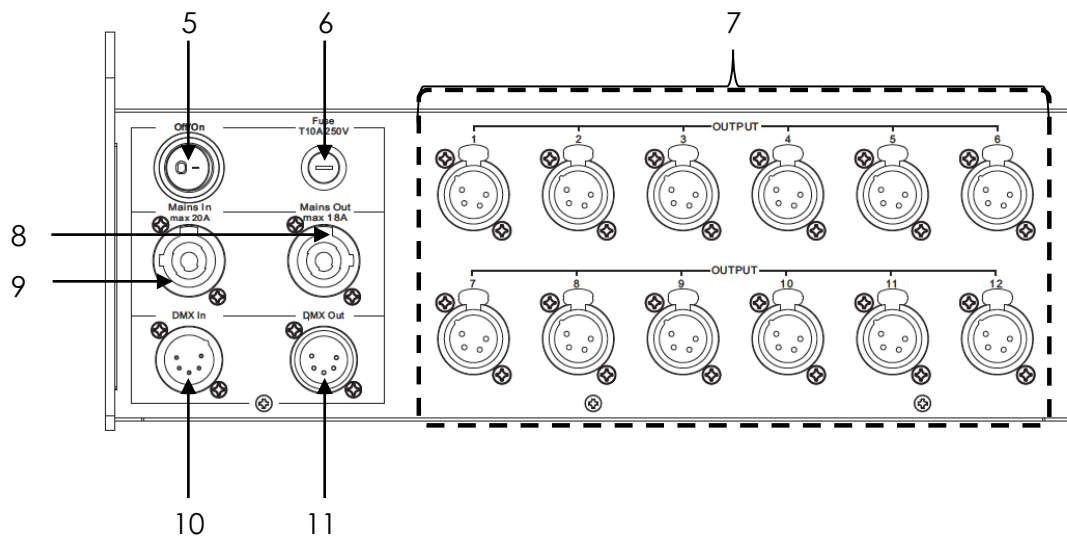

- |  |                                |
|--|--------------------------------|
| 5. Mains switch (on / off)             | 9. Mains Input (blue powerCON) |
| 6. Micro-fuse 5 x 20mm, T5A @ 250V     | 10. DMX Input (XLR 5pin)       |
| 7. 12 x Output to Atom head (XLR 4pin) | 11. DMX Output (XLR 5pin)      |
| 8. Mains Output (white powerCON)       |                                |

## 2 Safety Instructions



The **X4 ATOM PSU 12** is a High-Tech Product.

To guarantee a smooth operation, it is necessary to respect the following rules. The manufacturer of this device will not take responsibility for damages through any disregard of the information provided in this manual. Warranty claims also will be voided in the case that the fixture housing is opened.



**Never look directly into the beam of light or into the LED.**

**Attention:** LED Class 2M can cause injuries of your eyes even without optical instruments in front of them or within a distance of less than 0.5m and short exposure time.

Hence: Avoid direct radiation into your eyes!

1. Before powering on the fixture, make sure that the fixtures fans and air inlets are clean and not blocked.
2. **The fixture doesn't contain any user serviceable parts. Opening the fixture will void all warranties.**
3. It is necessary to wait at least 15 minutes after disconnecting the mains power before handling the fixture. Pay attention to possible hot parts of the fixture.
4. To ensure safe operation, follow also the Installation guide described in the chapter below. Operating the **X4 ATOM PSU 12** without suitable safety aids like Safety cables or clamps/hooks can increase the risk of an accident and must be avoided.
5. Repair, maintenance, and installation work shall be done by qualified or GLP certified staff only. You need to pay attention to the common rules of technology that are not explicitly mentioned in this manual.
6. Use only original GLP spare parts. Any structural modification of the system will terminate all warranty claims.
7. Please keep this instruction manual for future reference.
8. Should you have any questions about the operation of your fixture then please contact your local GLP office, or their authorized distributor, a list of which can be found at [www.glp.de](http://www.glp.de).

### 3 Mounting

The **X4 ATOM PSU 12** is fully operational whether it hangs or is mounted to the wall. It can also be operated in a rack or standing on the floor or table. Keep a safety distance of min. 0.5 m towards any easily inflammable materials (decoration etc.).

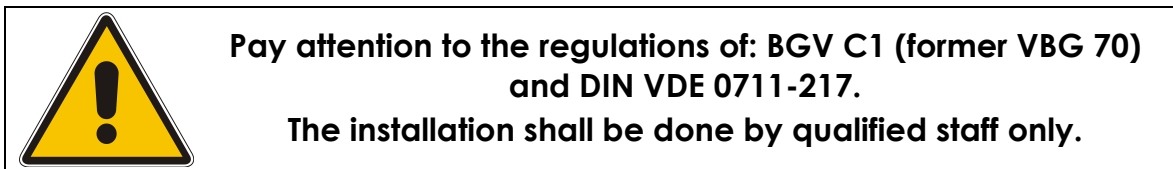

For the various mounting positions of the **X4 ATOM PSU 12** (sideways or hanging) different accessories kits are available. Through this a safe and firm installation is assured. You'll find dedicated connectors on the top side of the fixture which should be used.

#### 3.1 Operating on the floor, on a table or in a Rack

The **X4 ATOM PSU 12** can directly placed on the floor, a table or inside a rack. An additional securing is usually not required. Please pay attention to an even and gripping surface and keep at least 10cm space to each side for ventilation.

**Attention: Make sure not to not block any of the two fan in/outlets on either side of the fixture.**

#### 3.2 Mounting in a hanging or sideways position

To operate the **X4 ATOM PSU 12** in a hanging position an omega bracket can be mounted directly to the top side of the PSU using the two Camlock connectors.

It is fixed to the fixture with fasteners called Camlock quick-release connectors. Insert the two fasteners and turn each 90° to lock them. Do the opposite to release them again.

Alternatively a half-coupler (clamp or hook) can be mounted directly to the top side of the PSU using the M10 x 11mm thread bolt.

**Attention: Never use a longer bolt than 11mm as this may damage the interior of the fixture.**

### Top side view of the fixture:

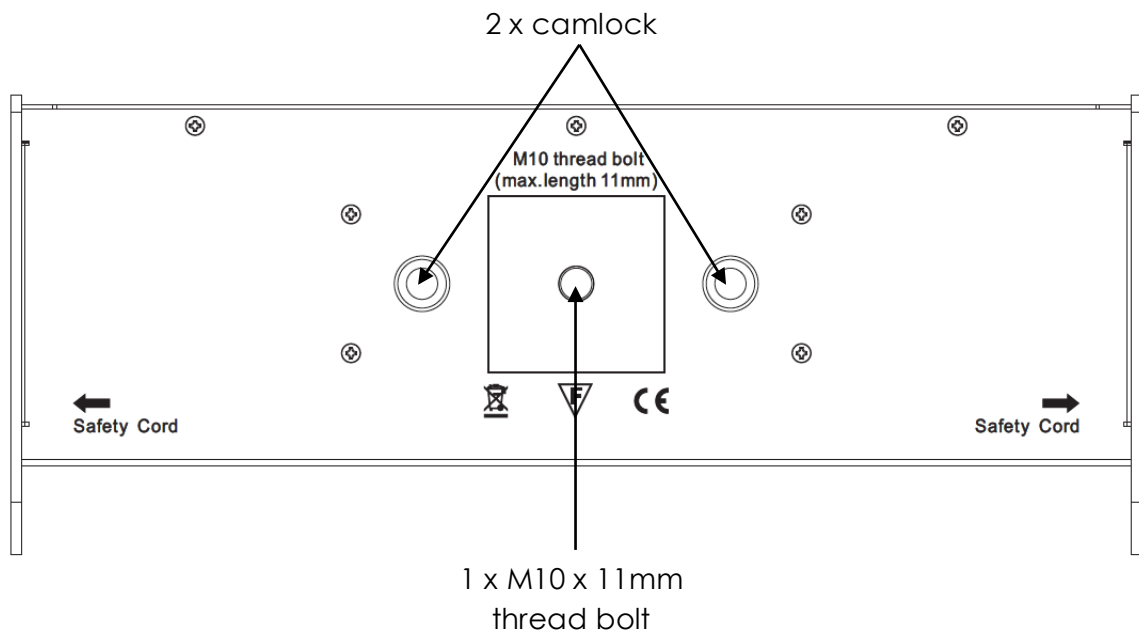

### 3.3 Securing the Fixture

Regardless of the mounting method of the **X4 ATOM PSU 12** you'll have to use a stipulated safety wire.

Attach the safety wire through the attachment point shown below and connect it to the primary support structure.

Pay attention to a safe and proper fastening. The safety cable must comply with BGI 810-3 (EN 60598-2-17 Section 17.6.6) and be capable of bearing a static suspended load that is ten times the weight of the fixture and all installed accessories.

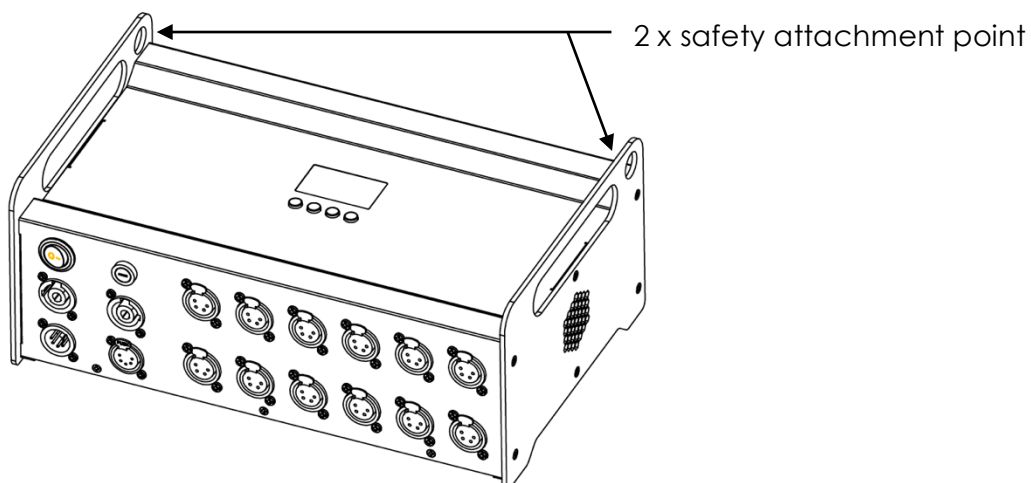

## 4 Connections

### 4.1 Power Supply

~90-240 Volt AC, 50-60 Hz, powerCON AC connector

Connected load max. 350 VA (Watt) / 25VA (Watt) per Atom head  
<=> T5A (micro-fuse 5x20mm)

Please see printing on the case for the right electronic supply!

**Always disconnect from the mains supply for changing the fuse and use only the above described micro-fuse type.**

NEUTRIK® powerCON

The **X4 ATOM PSU 12** is fitted with NEUTRIK® powerCON locking 3 conductor AC connectors.

The grey connector must be used to draw AC mains power from the fixtures` throughput sockets and the blue connectors must be used to supply power at the fixtures` power input socket.

The total number of fixtures in one interconnected chain depends on your local AC mains voltage but you must never connect more than a total load of 20A to stay within the limits of the connector. The total load includes all connected fixtures including the first one in the chain.

**Note: The maximum allowed total - load is 20A including the first fixture in one interconnected daisy chain.**

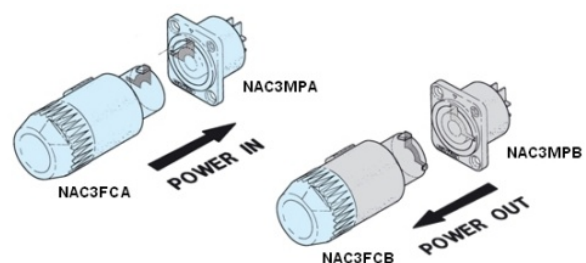

## 4.2 DMX

USITT DMX-512 Standard input/output in XLR 5-pin connectors.

Pin 1 = [Ground] / Pin 2 = [-] / Pin 3 = [+] / Pin 4 & 5 N.C.

The DMX- Addressing starts at the DMX- Address [001].

## 4.3 Output to X4 ATOM Head

12 x 4-pin XLR connectors for signal and power to Atom Head only.

Pin 1 = [Ground] / Pin 2 = [Data +] / Pin 3 = [Data -] / Pin 4 = [V+ 24V]

**Do not exceed 60m / 200ft. cable length for any output to the X4 ATOM head.**

**Attention: Do only connect one (1) GLP X4 ATOM head per output. Never connect any other equipment to this output as this may damage the PSU and/or the connected fixture(s).**

## 5 The Menu Field

You'll find the control board on the front side of the **X4 ATOM PSU 12**.

It allows you to make all necessary adjustments of the fixture. With the Mode-key you get into the main menu. Afterwards you can Navigate through the menu with the Up/Down-keys. Push the Enter-key to get in the next menu level or to confirm your settings. Make them and set functions ON/OFF with the Up/Down-keys. Confirm and save it with the Enter-key (the display shows OK). Push the Mode-key to cancel the entry and go back to the main menu.

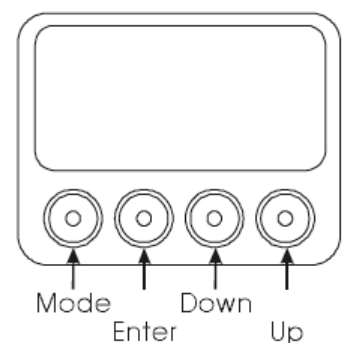

		← MODE - ENTER →			
↑ UP · DOWN · ↓ DOWN ←	Level1	Level 2	Level 3	Level 4	Remark
	DMX Start Address 001				Set the DMX start address
	Special	Manual DMX			Manual control of all fixture functions
			Master Intensity		Manual control for Master Intensity



← DOWN · UP →

	<b>Fixture</b>		Select fixture/output
	<b>Zoom</b>		Manual control for zoom
	<b>Speed Movements</b>		N/A
	<b>Special</b>		Manual control for Special functions
	<b>White Temperature</b>		Manual control for Color temperature
	<b>Dimmer</b>		Manual control for Dimmer
	<b>Shutter</b>		Manual control for Shutter
	<b>White</b>		Manual control for White
	<b>Blue</b>		Manual control for blue
	<b>Green</b>		Manual control for green
	<b>Red</b>		Manual control for red
	<b>Color Wheel</b>		Manual control for the color wheel
<b>Adjust</b>			
	<b>Key code xxxx</b>		Use the code for entering the calibration menu (for authorized persons only)
	<b>Display Contrast</b>		Adjustment for the Display contrast
	<b>PWM - Frequ. Adj.</b>		Changes PMW frequency
	<b>Max Zoom adjust</b>		Calibration of Zoom-offset
	<b>LED adjust</b>		
		<b>White adjust red</b>	Adjust intensity for red channel
		<b>White adjust blue</b>	Adjust intensity for blue channel
		<b>White adjust green</b>	Adjust intensity for green channel
	<b>Clear EEPROM</b>		Erase EEPROM memory
	<b>BL-Diagnose</b>		Diagnose of Boot-loader
	<b>Diagnose</b>		Diagnose fixture functions
<b>Default full feature</b>			Reset all settings to factory defaults
<b>Display Black out</b>			Auto switch-off display illumination after 10 seconds
<b>DMX hold</b>			Holds last DMX signal in case of signal loss
<b>DMX Image</b>			
	<b>Set image if DMX off</b>		Activates a stored scene if DMX is off
	<b>Save image in memory</b>		Stores the scene currently sent to the unit
<b>Set dimming mode</b>			Linear Dimming / Extr. soft dimming / Soft dimming
<b>DMX input Monitor</b>			Indicates the presently received DMX signal per DMX channel

	<b>Master Intensity</b>	Instantaneous value for Master Intensity
	<b>Fixture</b>	Instantaneous value for Fixture Sel.
	<b>Zoom</b>	Instantaneous value for Zoom
	<b>Speed Movements</b>	N/A
	<b>Special</b>	Instantaneous value for Special
	<b>White Temperature</b>	Adjustment of the color temperature
	<b>Dimmer</b>	Instantaneous value for Dimmer
	<b>Shutter</b>	Instantaneous value for Shutter
	<b>White</b>	Instantaneous value for White
	<b>Blue</b>	Instantaneous value for Blue
	<b>Green</b>	Instantaneous value for Green
	<b>Red</b>	Instantaneous value for Red
	<b>Color Wheel</b>	Instantaneous value for color wheel
<b>Self test program</b>		Initiates a self-test program
<b>Live time</b>		On-time of fixture
<b>Silent Mode</b>		Switch Silent Mode ON/OFF
<b>Reset</b>		RESET and new calibration for all functions

### Additional Display Indications

As a default you'll find the following additional information in the first row of the LCD display:

Vxx/xx/xx (e.g. V1.22/08/00)

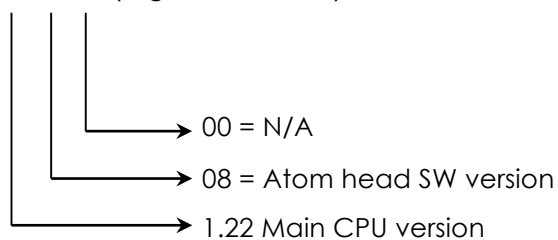

## 6 DMX Channel Selection (DMX Protocol)

### 6.1 Normal Mode (norm) 110 DMX Channels:

**Note:** We suggest to patch the Atom PSU as one 2 channel fixture and each connected Atom head as one 9 channel fixture.

Channel	Function	Time and Value	%	DMX
<b>PSU / Master Control</b>				
<b>1 Master Intensity</b>	Intensity of all connected Atom heads	0 - 100%	0..100	0..255
<b>2 Special</b> <i>for all fixtures</i>	No function		0..19	0..50
	Activate silent mode	> 1 sec	20..25	51..64
	No function		26..39	65..99
	Change PWM Frequency (582hz - 618hz)	> 1 sec	40..78	100..200
	Control all (copy output 1 to all outputs)	> 0.5 sec	79..97	201..247
	Reset all fixtures	> 0.5 sec	98..100	248..254
<b>Output 1</b>				
<b>3 Intensity</b>	Intensity	0 - 100%	0..100	0..255
<b>4 Shutter</b>	Shutter closed		0..5	0..15
	Random strobe	random / slow - fast	6..18	16..47
	Ramp up	random / slow - fast	19..31	48..79
	Ramp down	random / slow - fast	32..43	80..111
	Pulse	random / slow - fast	44..62	112..143
	Strobe with b/o pause	random / slow - fast	63..77	144..199
	Strobe - Slow to Fast	random / slow - fast	78..98	200..239
	Shutter Open		95..100	239..255
	<b>5 Color (fixed)</b>	Colors adjustable via RGB		0..2
Color 01 - Red <sup>1)</sup>			3..5	8..15
Color 02 - Amber <sup>1)</sup>			6..8	16..23
Color 03 - Warm Yellow <sup>1)</sup>			9..12	24..31
Color 04 - Yellow <sup>1)</sup>			13..15	32..39
Color 05 - Green <sup>1)</sup>			16..18	40..47
Color 06 - Turquoise <sup>1)</sup>			19..21	48..55
Color 07 - Cyan <sup>1)</sup>			22..24	56..63
Color 08 - Blue <sup>1)</sup>			25..27	64..71
Color 09 - Lavender <sup>1)</sup>			28..30	72..79
Color 10 - Malve <sup>1)</sup>			31..34	80..87
Color 11 - Magenta <sup>1)</sup>			35..37	88..95
Color 12 - Pink <sup>1)</sup>			38..40	96..103
White - CTO		3200K	41..43	104..111
White	5600K	44..46	112..119	

	White - CTB	7200K	47..49	120..127
	Rainbow Effect Stop <sup>2)</sup>		50	128
	Rainbow Effect <sup>3)</sup>	slow - fast	51..88	129..223
	Random colors	slow - fast	89..100	224..255
<b>6 Red</b>	Color mixing system - Red	0 - 100%	0..100	0..255
<b>7 Green</b>	Color mixing system - Green	0 - 100%	0..100	0..255
<b>8 Blue</b>	Color mixing system - Blue	0 - 100%	0..100	0..255
<b>9 White</b>	Color mixing system - White	0 - 100%	0..100	0..255
<b>10 Zoom</b>	Wide (flood) - narrow (spot)	34° - 3.5°	0..100	0..255
<b>11 CTO</b>	No function	Applicable for	0.3	0.7
	Variable CTO (10,000K - 2,700K)	all colors	4..100	8..255
<b>Output 2</b>				
<b>12 Intensity</b>	Intensity	0 - 100%	0..100	0..255
<b>13 Shutter</b>	Shutter closed		0.5	0.15
	Random strobe	random / slow - fast	6..18	16..47
	Ramp up	random / slow - fast	19..31	48..79
	Ramp down	random / slow - fast	32..43	80..111
	Pulse	random / slow - fast	44..62	112..143
	Strobe with b/o pause	random / slow - fast	63..77	144..199
	Strobe - Slow to Fast	random / slow - fast	78..98	200..239
	Shutter Open		95..100	239..255
<b>14 Color (fixed)</b>	Colors adjustable via RGB		0.2	0.7
	Color 01 - Red <sup>1)</sup>		3.5	8.15
	Color 02 - Amber <sup>1)</sup>		6.8	16..23
	Color 03 - Warm Yellow <sup>1)</sup>		9.12	24..31
	Color 04 - Yellow <sup>1)</sup>		13.15	32..39
	Color 05 - Green <sup>1)</sup>		16.18	40..47
	Color 06 - Turquoise <sup>1)</sup>		19..21	48..55
	Color 07 - Cyan <sup>1)</sup>		22..24	56..63
	Color 08 - Blue <sup>1)</sup>		25..27	64..71
	Color 09 - Lavender <sup>1)</sup>		28..30	72..79
	Color 10 - Malve <sup>1)</sup>		31..34	80..87
	Color 11 - Magenta <sup>1)</sup>		35..37	88..95
	Color 12 - Pink <sup>1)</sup>		38..40	96..103
	White - CTO	3200K	41..43	104..111
	White	5600K	44..46	112..119
	White - CTB	7200K	47..49	120..127
	Rainbow Effect Stop <sup>2)</sup>		50	128
	Rainbow Effect <sup>3)</sup>	slow - fast	51..88	129..223
	Random colors	slow - fast	89..100	224..255
<b>15 Red</b>	Color mixing system - Red	0 - 100%	0..100	0..255
<b>16 Green</b>	Color mixing system - Green	0 - 100%	0..100	0..255
<b>17 Blue</b>	Color mixing system - Blue	0 - 100%	0..100	0..255
<b>18 White</b>	Color mixing system - White	0 - 100%	0..100	0..255
<b>19 Zoom</b>	Wide (flood) - narrow (spot)	34° - 3.5°	0..100	0..255
<b>20 CTO</b>	No function	Applicable for	0.3	0.7
	Variable CTO (10,000K - 2,700K)	all colors	4..100	8..255

Output 3				
<b>21 Intensity</b>	Intensity	0 - 100%	0..100	0..255
<b>22 Shutter</b>	Shutter closed		0.5	0..15
	Random strobe	random / slow - fast	6..18	16..47
	Ramp up	random / slow - fast	19..31	48..79
	Ramp down	random / slow - fast	32..43	80..111
	Pulse	random / slow - fast	44..62	112..143
	Strobe with b/o pause	random / slow - fast	63..77	144..199
	Strobe - Slow to Fast	random / slow - fast	78..98	200..239
	Shutter Open		95..100	239..255
<b>23 Color (fixed)</b>	Colors adjustable via RGB		0.2	0.7
	Color 01 - Red <sup>1)</sup>		3.5	8..15
	Color 02 - Amber <sup>1)</sup>		6.8	16..23
	Color 03 - Warm Yellow <sup>1)</sup>		9.12	24..31
	Color 04 - Yellow <sup>1)</sup>		13..15	32..39
	Color 05 - Green <sup>1)</sup>		16..18	40..47
	Color 06 - Turquoise <sup>1)</sup>		19..21	48..55
	Color 07 - Cyan <sup>1)</sup>		22..24	56..63
	Color 08 - Blue <sup>1)</sup>		25..27	64..71
	Color 09 - Lavender <sup>1)</sup>		28..30	72..79
	Color 10 - Malve <sup>1)</sup>		31..34	80..87
	Color 11 - Magenta <sup>1)</sup>		35..37	88..95
	Color 12 - Pink <sup>1)</sup>		38..40	96..103
	White - CTO	3200K	41..43	104..111
	White	5600K	44..46	112..119
White - CTB	7200K	47..49	120..127	
Rainbow Effect Stop <sup>2)</sup>		50	128	
Rainbow Effect <sup>3)</sup>	slow - fast	51..88	129..223	
Random colors	slow - fast	89..100	224..255	
<b>24 Red</b>	Color mixing system - Red	0 - 100%	0..100	0..255
<b>25 Green</b>	Color mixing system - Green	0 - 100%	0..100	0..255
<b>26 Blue</b>	Color mixing system - Blue	0 - 100%	0..100	0..255
<b>27 White</b>	Color mixing system - White	0 - 100%	0..100	0..255
<b>28 Zoom</b>	Wide (flood) - narrow (spot)	34° - 3.5°	0..100	0..255
<b>29 CTO</b>	No function	Applicable for	0.3	0.7
	Variable CTO (10,000K - 2,700K)	all colors	4..100	8..255
Output 4				
<b>30 Intensity</b>	Intensity	0 - 100%	0..100	0..255
<b>31 Shutter</b>	Shutter closed		0.5	0..15
	Random strobe	random / slow - fast	6..18	16..47
	Ramp up	random / slow - fast	19..31	48..79
	Ramp down	random / slow - fast	32..43	80..111
	Pulse	random / slow - fast	44..62	112..143
	Strobe with b/o pause	random / slow - fast	63..77	144..199
	Strobe - Slow to Fast	random / slow - fast	78..98	200..239
	Shutter Open		95..100	239..255
<b>32 Color (fixed)</b>	Colors adjustable via RGB		0.2	0.7
	Color 01 - Red <sup>1)</sup>		3.5	8..15
	Color 02 - Amber <sup>1)</sup>		6.8	16..23
	Color 03 - Warm Yellow <sup>1)</sup>		9.12	24..31
	Color 04 - Yellow <sup>1)</sup>		13..15	32..39
	Color 05 - Green <sup>1)</sup>		16..18	40..47
	Color 06 - Turquoise <sup>1)</sup>		19..21	48..55
	Color 07 - Cyan <sup>1)</sup>		22..24	56..63
	Color 08 - Blue <sup>1)</sup>		25..27	64..71
	Color 09 - Lavender <sup>1)</sup>		28..30	72..79

	Color 10 - Malve <sup>1)</sup>		31..34	80..87
	Color 11 - Magenta <sup>1)</sup>		35..37	88..95
	Color 12 - Pink <sup>1)</sup>		38..40	96..103
	White - CTO	3200K	41..43	104..111
	White	5600K	44..46	112..119
	White - CTB	7200K	47..49	120..127
	Rainbow Effect Stop <sup>2)</sup>		50	128
	Rainbow Effect <sup>3)</sup>	slow - fast	51..88	129..223
	Random colors	slow - fast	89..100	224..255
<b>33 Red</b>	Color mixing system - Red	0 - 100%	0..100	0..255
<b>34 Green</b>	Color mixing system - Green	0 - 100%	0..100	0..255
<b>35 Blue</b>	Color mixing system - Blue	0 - 100%	0..100	0..255
<b>36 White</b>	Color mixing system - White	0 - 100%	0..100	0..255
<b>37 Zoom</b>	Wide (flood) - narrow (spot)	34° - 3.5°	0..100	0..255
<b>38 CTO</b>	No function	Applicable for	0..3	0..7
	Variable CTO (10,000K - 2,700K)	all colors	4..100	8..255
<b>Output 5</b>				
<b>39 Intensity</b>	Intensity	0 - 100%	0..100	0..255
<b>40 Shutter</b>	Shutter closed		0..5	0..15
	Random strobe	random / slow - fast	6..18	16..47
	Ramp up	random / slow - fast	19..31	48..79
	Ramp down	random / slow - fast	32..43	80..111
	Pulse	random / slow - fast	44..62	112..143
	Strobe with b/o pause	random / slow - fast	63..77	144..199
	Strobe - Slow to Fast	random / slow - fast	78..98	200..239
	Shutter Open		95..100	239..255
<b>41 Color (fixed)</b>	Colors adjustable via RGB		0..2	0..7
	Color 01 - Red <sup>1)</sup>		3..5	8..15
	Color 02 - Amber <sup>1)</sup>		6..8	16..23
	Color 03 - Warm Yellow <sup>1)</sup>		9..12	24..31
	Color 04 - Yellow <sup>1)</sup>		13..15	32..39
	Color 05 - Green <sup>1)</sup>		16..18	40..47
	Color 06 - Turquoise <sup>1)</sup>		19..21	48..55
	Color 07 - Cyan <sup>1)</sup>		22..24	56..63
	Color 08 - Blue <sup>1)</sup>		25..27	64..71
	Color 09 - Lavender <sup>1)</sup>		28..30	72..79
	Color 10 - Malve <sup>1)</sup>		31..34	80..87
	Color 11 - Magenta <sup>1)</sup>		35..37	88..95
	Color 12 - Pink <sup>1)</sup>		38..40	96..103
	White - CTO	3200K	41..43	104..111
	White	5600K	44..46	112..119
	White - CTB	7200K	47..49	120..127
	Rainbow Effect Stop <sup>2)</sup>		50	128
	Rainbow Effect <sup>3)</sup>	slow - fast	51..88	129..223
	Random colors	slow - fast	89..100	224..255
<b>41 Red</b>	Color mixing system - Red	0 - 100%	0..100	0..255
<b>43 Green</b>	Color mixing system - Green	0 - 100%	0..100	0..255
<b>44 Blue</b>	Color mixing system - Blue	0 - 100%	0..100	0..255
<b>45 White</b>	Color mixing system - White	0 - 100%	0..100	0..255
<b>46 Zoom</b>	Wide (flood) - narrow (spot)	34° - 3.5°	0..100	0..255
<b>47 CTO</b>	No function	Applicable for	0..3	0..7
	Variable CTO (10,000K - 2,700K)	all colors	4..100	8..255
<b>Output 6</b>				
<b>48 Intensity</b>	Intensity	0 - 100%	0..100	0..255
<b>49 Shutter</b>	Shutter closed		0..5	0..15

	Random strobe	random / slow - fast	6..18	16..47
	Ramp up	random / slow - fast	19..31	48..79
	Ramp down	random / slow - fast	32..43	80..111
	Pulse	random / slow - fast	44..62	112..143
	Strobe with b/o pause	random / slow - fast	63..77	144..199
	Strobe - Slow to Fast	random / slow - fast	78..98	200..239
	Shutter Open		95..100	239..255
<b>50 Color (fixed)</b>	Colors adjustable via RGB		0..2	0..7
	Color 01 - Red <sup>1)</sup>		3..5	8..15
	Color 02 - Amber <sup>1)</sup>		6..8	16..23
	Color 03 - Warm Yellow <sup>1)</sup>		9..12	24..31
	Color 04 - Yellow <sup>1)</sup>		13..15	32..39
	Color 05 - Green <sup>1)</sup>		16..18	40..47
	Color 06 - Turquoise <sup>1)</sup>		19..21	48..55
	Color 07 - Cyan <sup>1)</sup>		22..24	56..63
	Color 08 - Blue <sup>1)</sup>		25..27	64..71
	Color 09 - Lavender <sup>1)</sup>		28..30	72..79
	Color 10 - Malve <sup>1)</sup>		31..34	80..87
	Color 11 - Magenta <sup>1)</sup>		35..37	88..95
	Color 12 - Pink <sup>1)</sup>		38..40	96..103
	White - CTO	3200K	41..43	104..111
	White	5600K	44..46	112..119
	White - CTB	7200K	47..49	120..127
	Rainbow Effect Stop <sup>2)</sup>		50	128
	Rainbow Effect <sup>3)</sup>	slow - fast	51..88	129..223
	Random colors	slow - fast	89..100	224..255
<b>51 Red</b>	Color mixing system - Red	0 - 100%	0..100	0..255
<b>52 Green</b>	Color mixing system - Green	0 - 100%	0..100	0..255
<b>53 Blue</b>	Color mixing system - Blue	0 - 100%	0..100	0..255
<b>54 White</b>	Color mixing system - White	0 - 100%	0..100	0..255
<b>55 Zoom</b>	Wide (flood) - narrow (spot)	34° - 3.5°	0..100	0..255
<b>56 CTO</b>	No function	Applicable for	0..3	0..7
	Variable CTO (10,000K - 2,700K)	all colors	4..100	8..255
<b>Output 7</b>				
<b>57 Intensity</b>	Intensity	0 - 100%	0..100	0..255
<b>58 Shutter</b>	Shutter closed		0..5	0..15
	Random strobe	random / slow - fast	6..18	16..47
	Ramp up	random / slow - fast	19..31	48..79
	Ramp down	random / slow - fast	32..43	80..111
	Pulse	random / slow - fast	44..62	112..143
	Strobe with b/o pause	random / slow - fast	63..77	144..199
	Strobe - Slow to Fast	random / slow - fast	78..98	200..239
	Shutter Open		95..100	239..255
<b>59 Color (fixed)</b>	Colors adjustable via RGB		0..2	0..7
	Color 01 - Red <sup>1)</sup>		3..5	8..15
	Color 02 - Amber <sup>1)</sup>		6..8	16..23
	Color 03 - Warm Yellow <sup>1)</sup>		9..12	24..31
	Color 04 - Yellow <sup>1)</sup>		13..15	32..39
	Color 05 - Green <sup>1)</sup>		16..18	40..47
	Color 06 - Turquoise <sup>1)</sup>		19..21	48..55
	Color 07 - Cyan <sup>1)</sup>		22..24	56..63
	Color 08 - Blue <sup>1)</sup>		25..27	64..71
	Color 09 - Lavender <sup>1)</sup>		28..30	72..79
	Color 10 - Malve <sup>1)</sup>		31..34	80..87
	Color 11 - Magenta <sup>1)</sup>		35..37	88..95
	Color 12 - Pink <sup>1)</sup>		38..40	96..103

	White - CTO	3200K	41..43	104..111
	White	5600K	44..46	112..119
	White - CTB	7200K	47..49	120..127
	Rainbow Effect Stop <sup>2)</sup>		50	128
	Rainbow Effect <sup>3)</sup>	slow - fast	51..88	129..223
	Random colors	slow - fast	89..100	224..255
<b>60 Red</b>	Color mixing system - Red	0 - 100%	0..100	0..255
<b>61 Green</b>	Color mixing system - Green	0 - 100%	0..100	0..255
<b>62 Blue</b>	Color mixing system - Blue	0 - 100%	0..100	0..255
<b>63 White</b>	Color mixing system - White	0 - 100%	0..100	0..255
<b>64 Zoom</b>	Wide (flood) - narrow (spot)	34° - 3.5°	0..100	0..255
<b>65 CTO</b>	No function	Applicable for	0.3	0.7
	Variable CTO (10,000K - 2,700K)	all colors	4..100	8..255
<b>Output 8</b>				
<b>66 Intensity</b>	Intensity	0 - 100%	0..100	0..255
<b>67 Shutter</b>	Shutter closed		0.5	0..15
	Random strobe	random / slow - fast	6..18	16..47
	Ramp up	random / slow - fast	19..31	48..79
	Ramp down	random / slow - fast	32..43	80..111
	Pulse	random / slow - fast	44..62	112..143
	Strobe with b/o pause	random / slow - fast	63..77	144..199
	Strobe - Slow to Fast	random / slow - fast	78..98	200..239
	Shutter Open		95..100	239..255
<b>68 Color (fixed)</b>	Colors adjustable via RGB		0..2	0..7
	Color 01 - Red <sup>1)</sup>		3..5	8..15
	Color 02 - Amber <sup>1)</sup>		6..8	16..23
	Color 03 - Warm Yellow <sup>1)</sup>		9..12	24..31
	Color 04 - Yellow <sup>1)</sup>		13..15	32..39
	Color 05 - Green <sup>1)</sup>		16..18	40..47
	Color 06 - Turquoise <sup>1)</sup>		19..21	48..55
	Color 07 - Cyan <sup>1)</sup>		22..24	56..63
	Color 08 - Blue <sup>1)</sup>		25..27	64..71
	Color 09 - Lavender <sup>1)</sup>		28..30	72..79
	Color 10 - Malve <sup>1)</sup>		31..34	80..87
	Color 11 - Magenta <sup>1)</sup>		35..37	88..95
	Color 12 - Pink <sup>1)</sup>		38..40	96..103
	White - CTO	3200K	41..43	104..111
	White	5600K	44..46	112..119
	White - CTB	7200K	47..49	120..127
	Rainbow Effect Stop <sup>2)</sup>		50	128
	Rainbow Effect <sup>3)</sup>	slow - fast	51..88	129..223
	Random colors	slow - fast	89..100	224..255
<b>69 Red</b>	Color mixing system - Red	0 - 100%	0..100	0..255
<b>70 Green</b>	Color mixing system - Green	0 - 100%	0..100	0..255
<b>71 Blue</b>	Color mixing system - Blue	0 - 100%	0..100	0..255
<b>72 White</b>	Color mixing system - White	0 - 100%	0..100	0..255
<b>73 Zoom</b>	Wide (flood) - narrow (spot)	34° - 3.5°	0..100	0..255
<b>74 CTO</b>	No function	Applicable for	0.3	0.7
	Variable CTO (10,000K - 2,700K)	all colors	4..100	8..255
<b>Output 9</b>				
<b>75 Intensity</b>	Intensity	0 - 100%	0..100	0..255
<b>76 Shutter</b>	Shutter closed		0.5	0..15
	Random strobe	random / slow - fast	6..18	16..47
	Ramp up	random / slow - fast	19..31	48..79
	Ramp down	random / slow - fast	32..43	80..111



	Pulse	random / slow - fast	44..62	112..143
	Strobe with b/o pause	random / slow - fast	63..77	144..199
	Strobe - Slow to Fast	random / slow - fast	78..98	200..239
	Shutter Open		95..100	239..255
<b>77 Color (fixed)</b>	Colors adjustable via RGB		0..2	0..7
	Color 01 - Red <sup>1)</sup>		3..5	8..15
	Color 02 - Amber <sup>1)</sup>		6..8	16..23
	Color 03 - Warm Yellow <sup>1)</sup>		9..12	24..31
	Color 04 - Yellow <sup>1)</sup>		13..15	32..39
	Color 05 - Green <sup>1)</sup>		16..18	40..47
	Color 06 - Turquoise <sup>1)</sup>		19..21	48..55
	Color 07 - Cyan <sup>1)</sup>		22..24	56..63
	Color 08 - Blue <sup>1)</sup>		25..27	64..71
	Color 09 - Lavender <sup>1)</sup>		28..30	72..79
	Color 10 - Malve <sup>1)</sup>		31..34	80..87
	Color 11 - Magenta <sup>1)</sup>		35..37	88..95
	Color 12 - Pink <sup>1)</sup>		38..40	96..103
	White - CTO	3200K	41..43	104..111
	White	5600K	44..46	112..119
	White - CTB	7200K	47..49	120..127
	Rainbow Effect Stop <sup>2)</sup>		50	128
	Rainbow Effect <sup>3)</sup>	slow - fast	51..88	129..223
	Random colors	slow - fast	89..100	224..255
<b>78 Red</b>	Color mixing system - Red	0 - 100%	0..100	0..255
<b>79 Green</b>	Color mixing system - Green	0 - 100%	0..100	0..255
<b>80 Blue</b>	Color mixing system - Blue	0 - 100%	0..100	0..255
<b>81 White</b>	Color mixing system - White	0 - 100%	0..100	0..255
<b>82 Zoom</b>	Wide (flood) - narrow (spot)	34° - 3.5°	0..100	0..255
<b>83 CTO</b>	No function Variable CTO (10,000K - 2,700K)	Applicable for all colors	0..3 4..100	0..7 8..255
<b>Output 10</b>				
<b>84 Intensity</b>	Intensity	0 - 100%	0..100	0..255
<b>85 Shutter</b>	Shutter closed		0..5	0..15
	Random strobe	random / slow - fast	6..18	16..47
	Ramp up	random / slow - fast	19..31	48..79
	Ramp down	random / slow - fast	32..43	80..111
	Pulse	random / slow - fast	44..62	112..143
	Strobe with b/o pause	random / slow - fast	63..77	144..199
	Strobe - Slow to Fast	random / slow - fast	78..98	200..239
	Shutter Open		95..100	239..255
<b>86 Color (fixed)</b>	Colors adjustable via RGB		0..2	0..7
	Color 01 - Red <sup>1)</sup>		3..5	8..15
	Color 02 - Amber <sup>1)</sup>		6..8	16..23
	Color 03 - Warm Yellow <sup>1)</sup>		9..12	24..31
	Color 04 - Yellow <sup>1)</sup>		13..15	32..39
	Color 05 - Green <sup>1)</sup>		16..18	40..47
	Color 06 - Turquoise <sup>1)</sup>		19..21	48..55
	Color 07 - Cyan <sup>1)</sup>		22..24	56..63
	Color 08 - Blue <sup>1)</sup>		25..27	64..71
	Color 09 - Lavender <sup>1)</sup>		28..30	72..79
	Color 10 - Malve <sup>1)</sup>		31..34	80..87
	Color 11 - Magenta <sup>1)</sup>		35..37	88..95
	Color 12 - Pink <sup>1)</sup>		38..40	96..103
	White - CTO	3200K	41..43	104..111
	White	5600K	44..46	112..119
	White - CTB	7200K	47..49	120..127

	Rainbow Effect Stop <sup>2)</sup>		50	128
	Rainbow Effect <sup>3)</sup>	slow - fast	51..88	129..223
	Random colors	slow - fast	89..100	224..255
<b>87 Red</b>	Color mixing system - Red	0 - 100%	0..100	0..255
<b>88 Green</b>	Color mixing system - Green	0 - 100%	0..100	0..255
<b>89 Blue</b>	Color mixing system - Blue	0 - 100%	0..100	0..255
<b>90 White</b>	Color mixing system - White	0 - 100%	0..100	0..255
<b>91 Zoom</b>	Wide (flood) - narrow (spot)	34° - 3.5°	0..100	0..255
<b>92 CTO</b>	No function	Applicable for	0.3	0.7
	Variable CTO (10,000K - 2,700K)	all colors	4..100	8..255
<b>Output 11</b>				
<b>93 Intensity</b>	Intensity	0 - 100%	0..100	0..255
<b>94 Shutter</b>	Shutter closed		0.5	0..15
	Random strobe	random / slow - fast	6..18	16..47
	Ramp up	random / slow - fast	19..31	48..79
	Ramp down	random / slow - fast	32..43	80..111
	Pulse	random / slow - fast	44..62	112..143
	Strobe with blackout pause	random / slow - fast	63..77	144..199
	Strobe - Slow to Fast	random / slow - fast	78..98	200..239
	Shutter Open		95..100	239..255
<b>95 Color (fixed)</b>	Colors adjustable via RGB		0..2	0..7
	Color 01 - Red <sup>1)</sup>		3..5	8..15
	Color 02 - Amber <sup>1)</sup>		6..8	16..23
	Color 03 - Warm Yellow <sup>1)</sup>		9..12	24..31
	Color 04 - Yellow <sup>1)</sup>		13..15	32..39
	Color 05 - Green <sup>1)</sup>		16..18	40..47
	Color 06 - Turquoise <sup>1)</sup>		19..21	48..55
	Color 07 - Cyan <sup>1)</sup>		22..24	56..63
	Color 08 - Blue <sup>1)</sup>		25..27	64..71
	Color 09 - Lavender <sup>1)</sup>		28..30	72..79
	Color 10 - Malve <sup>1)</sup>		31..34	80..87
	Color 11 - Magenta <sup>1)</sup>		35..37	88..95
	Color 12 - Pink <sup>1)</sup>		38..40	96..103
	White - CTO	3200K	41..43	104..111
	White	5600K	44..46	112..119
	White - CTB	7200K	47..49	120..127
	Rainbow Effect Stop <sup>2)</sup>		50	128
	Rainbow Effect <sup>3)</sup>	slow - fast	51..88	129..223
	Random colors	slow - fast	89..100	224..255
<b>96 Red</b>	Color mixing system - Red	0 - 100%	0..100	0..255
<b>97 Green</b>	Color mixing system - Green	0 - 100%	0..100	0..255
<b>98 Blue</b>	Color mixing system - Blue	0 - 100%	0..100	0..255
<b>99 White</b>	Color mixing system - White	0 - 100%	0..100	0..255
<b>100 Zoom</b>	Wide (flood) - narrow (spot)	34° - 3.5°	0..100	0..255
<b>101 CTO</b>	No function	Applicable for	0.3	0.7
	Variable CTO (10,000K - 2,700K)	all colors	4..100	8..255
<b>Output 12</b>				
<b>102 Intensity</b>	Intensity	0 - 100%	0..100	0..255
<b>103 Shutter</b>	Shutter closed		0.5	0..15
	Random strobe	random / slow - fast	6..18	16..47
	Ramp up	random / slow - fast	19..31	48..79
	Ramp down	random / slow - fast	32..43	80..111
	Pulse	random / slow - fast	44..62	112..143
	Strobe with b/o pause	random / slow - fast	63..77	144..199
	Strobe - Slow to Fast	random / slow - fast	78..98	200..239

	Shutter Open		95..100	239..255	
<b>104 Color (fixed)</b>	Colors adjustable via RGB		0..2	0..7	
	Color 01 - Red <sup>1)</sup>		3..5	8..15	
	Color 02 - Amber <sup>1)</sup>		6..8	16..23	
	Color 03 - Warm Yellow <sup>1)</sup>		9..12	24..31	
	Color 04 - Yellow <sup>1)</sup>		13..15	32..39	
	Color 05 - Green <sup>1)</sup>		16..18	40..47	
	Color 06 - Turquoise <sup>1)</sup>		19..21	48..55	
	Color 07 - Cyan <sup>1)</sup>		22..24	56..63	
	Color 08 - Blue <sup>1)</sup>		25..27	64..71	
	Color 09 - Lavender <sup>1)</sup>		28..30	72..79	
	Color 10 - Malve <sup>1)</sup>		31..34	80..87	
	Color 11 - Magenta <sup>1)</sup>		35..37	88..95	
	Color 12 - Pink <sup>1)</sup>		38..40	96..103	
	White - CTO	3200K		41..43	104..111
	White	5600K		44..46	112..119
	White - CTB	7200K		47..49	120..127
Rainbow Effect Stop <sup>2)</sup>			50	128	
Rainbow Effect <sup>3)</sup>	slow - fast		51..88	129..223	
Random colors	slow - fast		89..100	224..255	
<b>105 Red</b>	Color mixing system - Red	0 - 100%	0..100	0..255	
<b>106 Green</b>	Color mixing system - Green	0 - 100%	0..100	0..255	
<b>107 Blue</b>	Color mixing system - Blue	0 - 100%	0..100	0..255	
<b>108 White</b>	Color mixing system - White	0 - 100%	0..100	0..255	
<b>109 Zoom</b>	Wide (flood) - narrow (spot)	34° - 3.5°	0..100	0..255	
<b>110 CTO</b>	No function	Applicable for	0..3	0..7	
	Variable CTO (10,000K - 2,700K)	all colors	4..100	8..255	

<sup>1)</sup> The predefined colors can be used as start-colors for the Rainbow effect. Please select first a desired start-color before you activate the rainbow effect. All X4 Atom will then start from that color and will execute the rainbow effect synchronously. Different X4 Atom can have different start-colors but will still execute the rainbow effect synchronously. If you choose a color different from the ones marked with <sup>1)</sup> in the tables above the rainbow start-color will be red.

<sup>2)</sup> Rainbow-effect Stop will pause this function. After resuming the rainbow-effect will be continued from the current color.

<sup>3)</sup> The Rainbow-effect will run synchronously only if started from one of the predefined colors (see also <sup>1)</sup> before).

## 7 Maintaining and Cleaning

The **X4 ATOM PSU 12** is a fixture of very low maintenance. It is only necessary to clean the air inlets and outlets from time to time. For safe operation it is absolutely essential that the fixture is kept clean and that dust, dirt and smoke-fluid residues must not build up on, or within the fixture. Otherwise the fixture's cooling will be significantly reduced or damages can occur. Regular cleaning will not only ensure the maximum performance, but will also allow the fixture to operate reliably throughout its life.

### 7.1 Safety regulations

- **Pull out the mains power plug!**
- **Wait min. 15 minutes after disconnecting power to allow the fixture to cool down.**

### 7.2 Maintenance and Interval (rule-of-thumb)

The contamination of the fixture depends on the environment details. Hence no general guidelines can be given. The intervals given below are only suggestions from our experience.

Position	Interval	In this way
Fan and air channel	monthly	vacuum cleaner, airbrush, etc.

## 8 Technical Specifications:

<b>Power supply</b>	
<b>Power consumption</b>	Max. 350 VA (Watt) / 25VA (Watt) per X4 Atom head
<b>Power input</b>	Auto sensing 90-240 V AC, 50-60 Hz
<b>Mains in connector</b>	PowerCON (blue) max 20A
<b>Mains out connector</b>	PowerCON (white) max 18A
<b>Output to Atom head</b>	12 x 4-pin XLR Power (24V) & Signal (RS-485) to X4 Atom head: Pin 1 = [Ground] Pin 2 = [Data +] Pin 3 = [Data -] Pin 4 = [V+ 24V]
<b>Max. cable length to Atom head</b>	60m per output 200ft per output
<b>Fuse protection</b>	Micro-fuse 5x20 mm, T10A
<b>Operational Parameters</b>	
<b>Max. Ambient Temperature</b>	5° - 45°C (integrated overheating switch) 40°-113°F
<b>Protection</b>	IP20 rated
<b>Mounting Position</b>	Any (see relevant chapter in the manual)
<b>Rigging Options</b>	
<b>1 x M10 socket</b>	For direct coupler
<b>2 x Camlock</b>	For omega bracket
<b>2 x Attachment point</b>	For safety wire
<b>Data Entry</b>	
Backlit Graphic LCD Display with 4 button control for addressing and other settings	
<b>DMX Control</b>	
Standard USITT DMX-512, 5-pin XLR: Pin 3 = [ + ] Pin 2 = [ - ] Pin 1 = [Ground] Pin 4 & 5 not connected The DMX- Addressing starts at the DMX channel [001]	
<b>Weights and Measures</b>	
<b>Length</b>	<b>314 mm / 12.38''</b>
<b>Width</b>	<b>197 mm / 7.75''</b>
<b>Height</b>	<b>108 mm / 4.25''</b>
<b>Weight (net)</b>	<b>4.1 kg / 9 lbs.</b>

## 9 Dimensions

